

DESIGN 4 SHUTTERS FOR MASONRY BLOCK STRUCTURES

Shutters Attached to Outside Wall with Permanently Mounted Brackets



One of the best ways to protect a home from damage in wind storms is to install shutters over all large windows and glass doors. Shutters protect doors and windows from wind-borne objects. They also prevent damage caused by sudden pressure changes when a window or door is broken.

This design guide from APA – *The Engineered Wood Association* describes how to construct structural panel shutters for attachment to masonry block buildings, using permanently mounted brackets on the outside wall. Two layers of APA Exterior plywood are attached to the outside of the concrete block wall with #10 flat-head screws in masonry anchors. Once the brackets are installed, no tools are required to install or remove the shutters unless stiffeners are required. It has the additional advantage of moving the shutter almost two inches farther away from the glass than shutters mounted to the interior of the window frame and is therefore less likely to require stiffeners. This publication also includes basic design considerations for all structural panel shutters. Additional designs

This APA hurricane shutter design is based on pressures associated with a design fastest-mile wind speed of 120 mph. Building codes are currently being reviewed for possible changes. Before constructing shutters, therefore, it is important to check with your local building department for an update on current code requirements.

from APA provide details for shutters that use alternative attachment systems and shutter designs for wood-frame buildings.

Design Considerations

General

Most building codes currently do not include provisions for storm shutters. For those codes that do, or have had provi-

sions in the past, the design requirements for these shutters generally call for a deflection of less than the shutter span (in inches) divided by 30 (for instance, a 40-inch span should not bend more than $40/30 = 1.33$ inches when the wind blows). They also should bend less than 2 inches maximum and should remain at least one inch away from the window when under full wind force.

TABLE 1

MAXIMUM SPAN WITHOUT STIFFENERS

APA Panel Span Rating	Approximate Weight (lb./ft. ²)	Maximum Shutter Span	Approximate Deflection (in.) at 120 mph Design Wind Speed at 15-ft. Height
32/16	1.5	30	0.5
40/20	2	36	0.5
48/24	2.4	48	0.9
48 oc	3.6	72	1.5

TABLE 2

ESTIMATED DEFLECTION AT 120 MPH DESIGN WIND SPEED AT 15-FT. HEIGHT FOR SHUTTERS WITH 2 X 4s AT 16 INCHES o.c.

APA Panel Span Rating	Approximate Weight (lb./ft. ²)	Shutter Span (in.)							
		24	36	48	60	72	84	96	
32/16	2.5	0.2	0.2	0.3	0.4	0.5	0.8	–	
40/20	2.9	0.1	0.1	0.2	0.2	0.4	0.7	1.1	
48/24	3.4	–	–	0.1	0.2	0.3	0.6	1.0	
48 oc	4.6	–	–	0.1	0.1	0.3	0.5	0.9	

A P A

The Engineered Wood Association

The easiest designs are those that simply cover the opening with a wood structural panel. In wood-frame construction, panels can be nailed over the openings when a hurricane approaches. Buildings made with concrete blocks, however, require advance preparation.

In some cases, stiffeners may be necessary to limit deflection of the shutter against the glass. Stiffeners function best if the 2 x 4s are on the outside of the shutter and oriented with the narrow edge against the shutter.

Note: The shutter designs shown herein will provide significant protection from hurricane-force winds. This publication contains recommendations to serve as a guide only. It does not include all possible shutter, anchor and fastening systems, and the installer must adjust all dimensions to compensate for particular installations and hardware used. These shutter designs by no means represent all possible workable designs and can always be upgraded to provide even greater margins of safety and protection. All shutter designs herein are intended to be temporary, and mounted and removed from outside the building. All designs are based on wind pressure capacities only.

While the design wind pressures used are based on ASCE 7-95, the building owner/installer must still carefully evaluate each system and then, if necessary, make any modifications consistent with good design and building practices.

Fasteners

Screws or bolts that will be permanently exposed to the weather should be made of stainless steel.

Anchorage to Masonry Block

The plastic anchors* referenced in this plan have sufficient lateral and withdrawal capacity to handle the expected forces and are recommended because they are rated as being vibration resistant – a characteristic that may be of some value under buffeting wind loads. (Standard lead anchors are not usually rated as vibration resistant.)

Keep masonry anchors at least 1-1/2 inches from the block edges, joints and corners to minimize the danger of cracking the concrete blocks.

*Withdrawal ultimate value 490 lbs. or greater in 4000 psi concrete, with screws specified (1-1/2 inches with stucco).

FIGURE 1
SHUTTER STIFFENER ATTACHMENT – IF REQUIRED

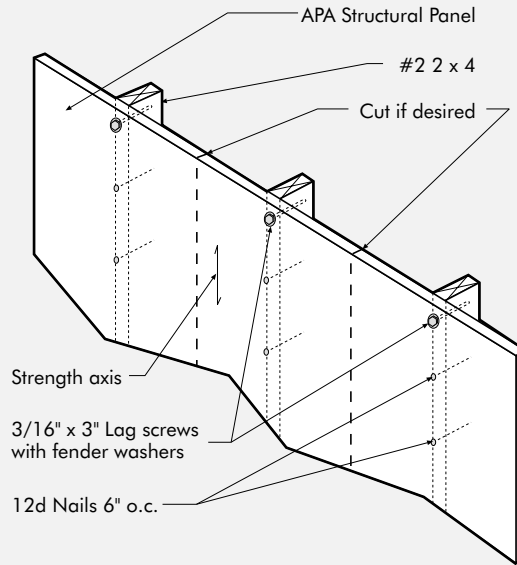

FIGURE 2
SHUTTER FRAME AND ATTACHMENT – STRUCTURAL PANEL OPTION

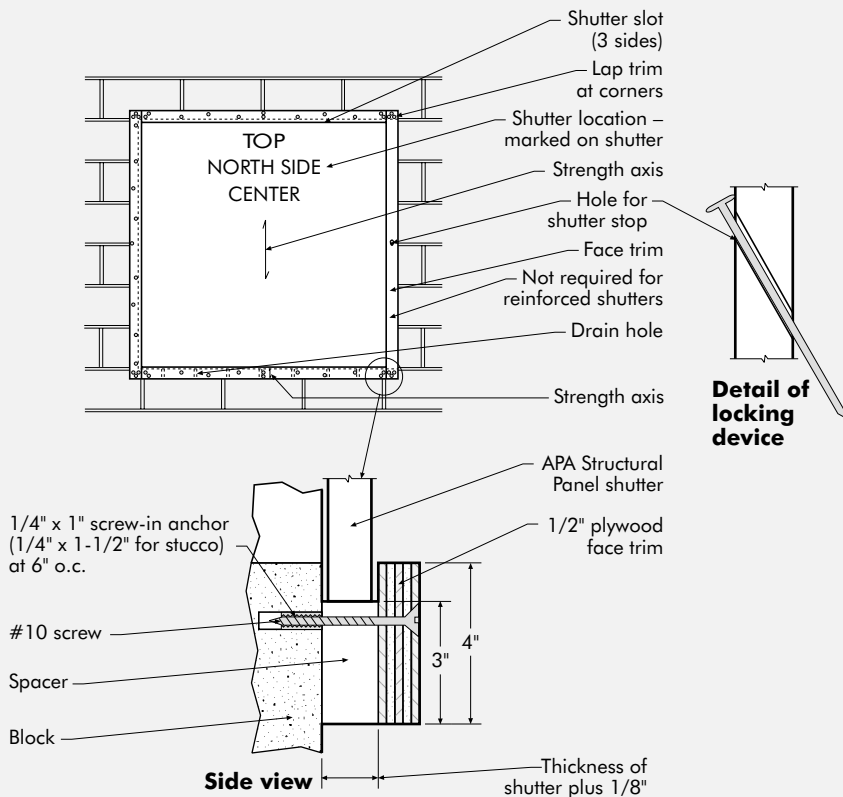
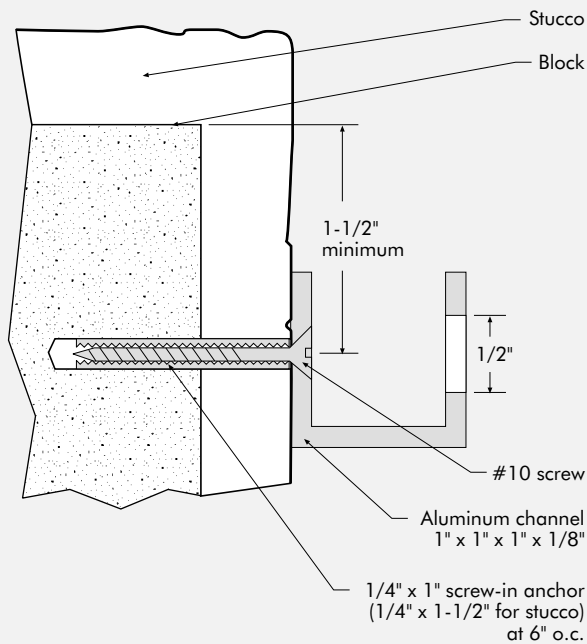

FIGURE 3

SHUTTER FRAME AND ATTACHMENT – ALUMINUM CHANNEL OPTION



Steps to Constructing Shutters

1. Use Tables 1 and 2 in the Design Considerations section to determine if stiffeners are needed. Attach stiffeners as shown in Figure 1.
2. Cut APA EXTERIOR plywood for the shutter support – window trim. Make the thickness of the inner spacer slightly greater than that of the shutter to allow the shutters to slide without binding. (The inner trim spacer of plywood is left out of one side of the window framing to allow for the insertion of the shutters.) Orient the plywood face grain of the trim as indicated in the diagram. (Plywood with four or more plies may be oriented either direction.) Lap the corners to allow the outer trim to be attached to the inner spacer at the corners. (Figure 2)
3. Drill 1/2-inch-diameter vertical drain holes in bottom inner spacer to allow rain water to escape out the bottom.
4. Cut the shutter to be 1/4 inch less than the distance from the bottom of the

- bottom slot to the top of the top slot, and about 2 inches wider than the window opening width (assuming that the panels are supported top and bottom). Orient the long panel axis (strength axis) as shown in Figure 1. Slide the shutter into place.
5. Drill hole halfway down the trim and diagonally downward (at about 30° from the surface) in the trim board covering the shutter entrance opening. The hole should be about 1/8 inch outside the edge of the installed shutter. This hole will receive a 12d box nail to prevent the shutter panel or panels from getting blown back out the entrance slot.
6. Any permanently installed hardware, shims or fastening devices must be installed using standard/acceptable methods of waterproofing. All abandoned holes must be sealed.
7. After fabrication each shutter should be marked for orientation and location to simplify installation.

Design Alternative

As an alternative to Design 4, the wood trim can be replaced with 1 x 1 x 1-inch (outside measurements) x 1/8-inch aluminum channels (channel outside dimensions may be changed to better accommodate panels thicker than 5/8 inch, i.e., 1-1/8-inch-thick shutters will require a channel slot opening of about 1-1/4 inches) mounted approximately the same way as the wood trim. (Figure 3) Make holes at both ends to hold a latching device to prevent shutters from being blown out.

Note: using sawn lumber instead of plywood for the outer layer of trim may result in the failure of the trim when suction loads are applied to the shutter.

Additional Hurricane Shutter Designs from APA – *The Engineered Wood Association*

APA offers a series of Hurricane Shutter Designs. They include:

- Design 1: Shutters for Wood-Frame Buildings
- Design 2: Shutters for Masonry Block Structures, *Barrel Bolt Latch Supports*
- Design 3: Shutters for Masonry Block Structures, *Steel or Aluminum Angle and Screw Supports*
- Design 4: Shutters for Masonry Block Structures, *Shutters Attached to Outside Wall with Permanently Mounted Brackets*
- Design 5: Shutters for Masonry Block Structures, *For Openings Wider than 8 Feet*

Each design is available from APA – *The Engineered Wood Association* for \$1. Designs may also be ordered as a complete set for \$5. To order, contact APA – *The Engineered Wood Association*, P.O. Box 11700, Tacoma, Washington 98411-0700. Phone: (253) 565-6600. Fax: (253) 565-7265.

We have field representatives in most major U.S. cities and in Canada who can help answer questions involving APA trademarked products. For additional assistance in specifying APA engineered wood products, get in touch with your nearest APA regional office. Call or write:

WESTERN REGION

7011 So. 19th St. ■ P.O. Box 11700
Tacoma, Washington 98411-0700
(253) 565-6600 ■ Fax: (253) 565-7265

EASTERN REGION

2130 Barrett Park Drive, Suite 102
Kennesaw, Georgia 30144-3681
(770) 427-9371 ■ Fax: (770) 423-1703

**U.S. HEADQUARTERS
AND INTERNATIONAL
MARKETING DIVISION**

7011 So. 19th St. ■ P.O. Box 11700
Tacoma, Washington 98411-0700
(253) 565-6600 ■ Fax: (253) 565-7265



www.apawood.org

PRODUCT SUPPORT HELP DESK

(253) 620-7400
E-mail Address: help@apawood.org

(Offices: Antwerp, Belgium; Bournemouth, United Kingdom; Hamburg, Germany; Mexico City, Mexico; Tokyo, Japan.) For Caribbean/Latin America, contact headquarters in Tacoma.

The product use recommendations in this publication are based on APA – The Engineered Wood Association’s continuing programs of laboratory testing, product research, and comprehensive field experience. However, because the Association has no control over quality of workmanship or the conditions under which engineered wood products are used, it cannot accept responsibility for product performance or designs as actually constructed. Because engineered wood product performance requirements vary geographically, consult your local architect, engineer or design professional to assure compliance with code, construction, and performance requirements.

Form No. T454D
Revised May 1997/0100

A P A

The Engineered Wood Association

